

Frese per incastri Z=12/18/24 - HM*Grooving cutter Z=12/18/24 - HM*

Fraises à rainier Z=12/18/24 - HM

Nutfräser Z=12/18/24 - HM

Fresa de ranurar Z=12/18/24 - MD

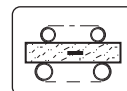

N° MAX:
 Ø140 - 9.000 Ø160 - 8.000
 Ø180 - 7.000 Ø200 - 6.000
 Ø250 - 5.000 Ø300 - 4.000

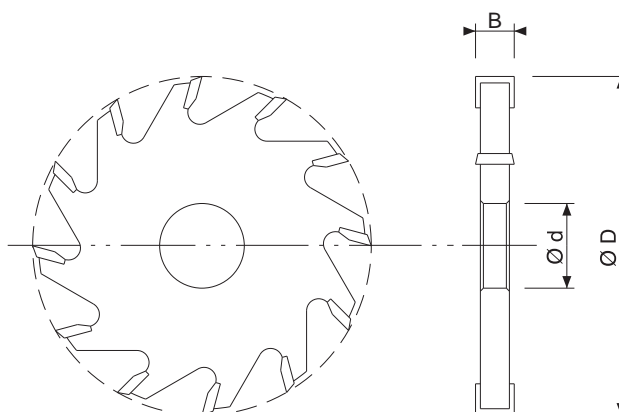

CODICE	ØD	B	Z
1.013.105	140	5	12
1.013.106	140	6	12
1.013.108	140	8	12
1.013.110	140	10	12
1.013.112	140	12	12
1.013.114	140	14	12
1.013.116	140	16	12
1.013.118	140	18	12
1.013.120	140	20	12
1.013.205	160	5	12
1.013.206	160	6	12
1.013.208	160	8	12
1.013.210	160	10	12
1.013.212	160	12	12
1.013.214	160	14	12
1.013.216	160	16	12
1.013.218	160	18	12
1.013.220	160	20	12
1.013.305	180	5	12
1.013.306	180	6	12
1.013.308	180	8	12
1.013.310	180	10	12
1.013.312	180	12	12
1.013.314	180	14	12
1.013.316	180	16	12
1.013.318	180	18	12
1.013.320	180	20	12

CODICE	ØD	B	Z
1.013.405	200	5	18
1.013.406	200	6	18
1.013.408	200	8	18
1.013.410	200	10	18
1.013.412	200	12	18
1.013.414	200	14	18
1.013.416	200	16	18
1.013.418	200	18	18
1.013.420	200	20	18
1.013.505	250	5	24
1.013.506	250	6	24
1.013.508	250	8	24
1.013.510	250	10	24
1.013.512	250	12	24
1.013.514	250	14	24
1.013.516	250	16	24
1.013.518	250	18	24
1.013.520	250	20	24
1.013.605	300	5	24
1.013.606	300	6	24
1.013.608	300	8	24
1.013.610	300	10	24
1.013.612	300	12	24
1.013.614	300	14	24
1.013.616	300	16	24
1.013.618	300	18	24
1.013.620	300	20	24